



modello: modell:	<b>ALEA</b>
codice: code:	<b>4281</b>
design:	<b>ABS studio</b>
anno - year:	<b>2006</b>
tipologia: typology:	<b>lampada a parete orientabile adjustable wall lamp</b>
materiali: materials:	<b>alluminio - PPS aluminium-PPS</b>
luce - light:	<b>diretta - direct</b>
lampadine - bulbs:	<b>20W G9 ECO vedi pag 2 33W G9 ECO vedi pag 2 48W G9 ECO vedi pag 2</b>
grado IP - IP grade:	<b>IP20</b>
peso netto - net weight:	<b>0,5 Kg</b>
finiture:	<b>.01 bianco .45 alluminio anodizzato</b>
finiture:	<b>.01 white .45 anodised aluminium</b>
Optionals:	<b>Art.0187, Art.0189 Art. 0205 - pag 2</b>
marcatura: marking:	<b>CE</b>
marchi costruttivi: symbols:	 

Dimensioni per il fissaggio a parete - Dimensions for wall fitting

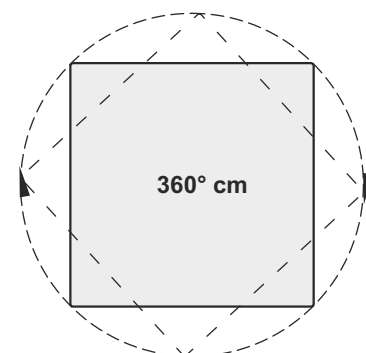
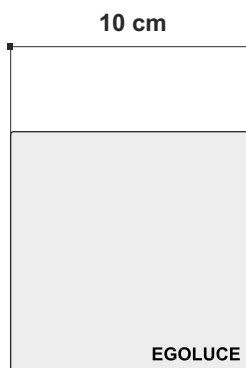
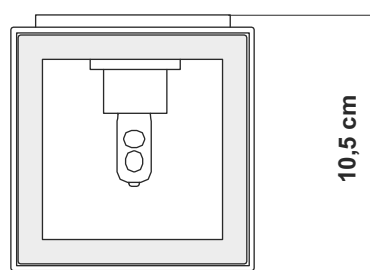
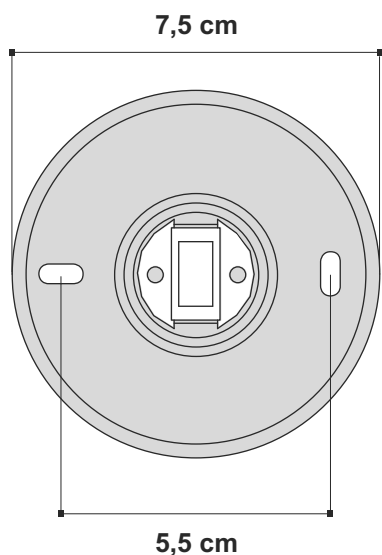

EGOLUCE s.r.l., via I.Newton 12 - 20016 Pero - Milano  
 telefono +39 02 339586.1 - fax. +39 02 3535112  
 e-mail: info@egoluce.com - http://www.egoluce.com

standard

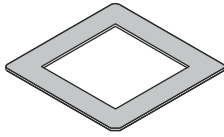

Art. 0189

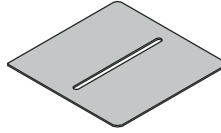

Art. 0187

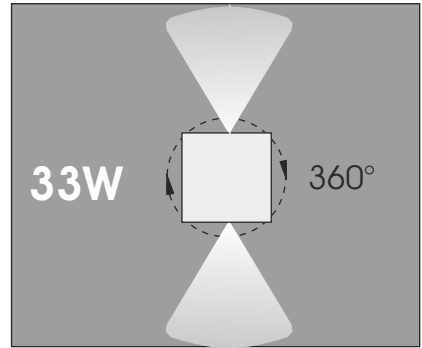
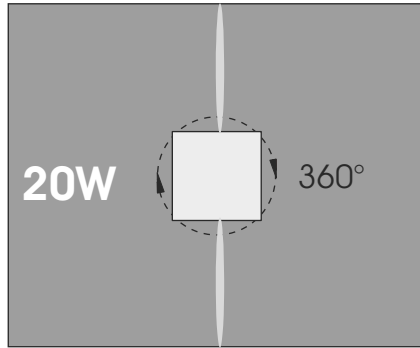
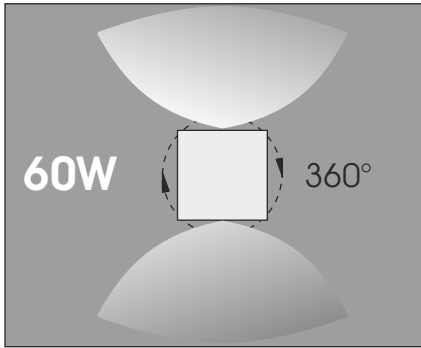
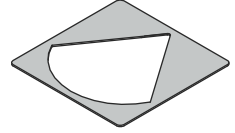

standard

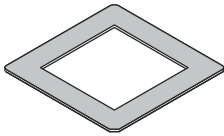

Art. 0189

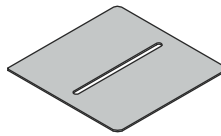

Art. 0187

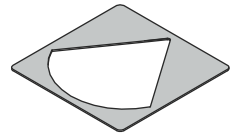

Art. 0205

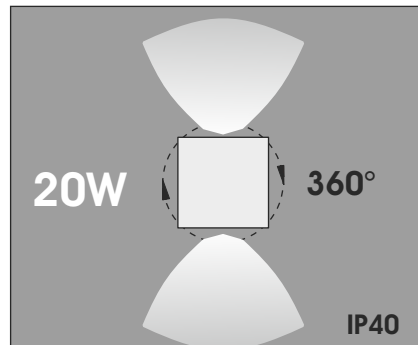
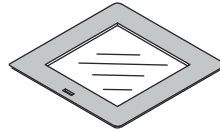

Art. 0205

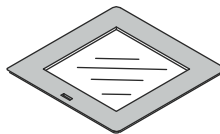

Art.0187

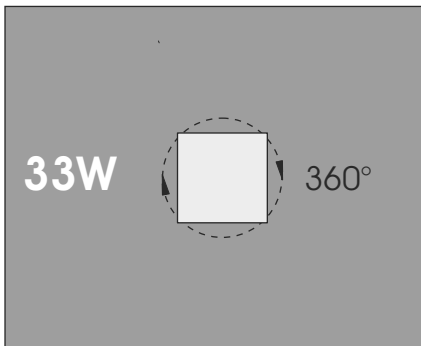

standard

Art.0189  
Art.0205

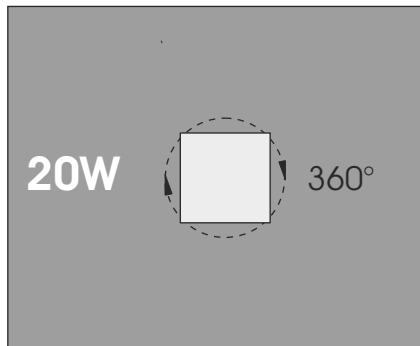

standard

Art.0189  
Art.0205

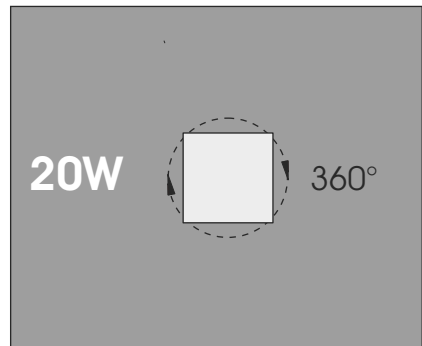

Art.0187



EGOLUCE s.r.l., via I. Newton 12 - 20016 Pero - Milano  
 telefono +39 02 339586.1 - fax. +39 02 3535112  
 e-mail: info@egoluce.com - http://www.egoluce.com

La presente scheda tecnica è di proprietà di EGOLUCE srl. Tutti i diritti sono riservati. Le fotografie, le descrizioni degli apparecchi, i disegni quotati ed i valori fotometrici menzionati sono a titolo indicativo e non costituiscono alcun impegno per la nostra società che si riserva di apportare, in qualsiasi momento e senza preavviso, tutte le modifiche che riterrà opportune.